

PROBLEM 1.1

Two solid cylindrical rods AB and BC are welded together at B and loaded as shown. Knowing that $d_1 = 30$ mm and $d_2 = 50$ mm, find the average normal stress at the midsection of (a) rod AB , (b) rod BC .

SOLUTION

(a) Rod AB :

Force: $P = 60 \times 10^3$ N tension

Area: $A = \frac{\pi}{4} d_1^2 = \frac{\pi}{4} (30 \times 10^{-3})^2 = 706.86 \times 10^{-6} \text{ m}^2$

Normal stress: $\sigma_{AB} = \frac{P}{A} = \frac{60 \times 10^3}{706.86 \times 10^{-6}} = 84.882 \times 10^6 \text{ Pa}$ $\sigma_{AB} = 84.9 \text{ MPa} \blacktriangleleft$

(b) Rod BC :

Force: $P = 60 \times 10^3 - (2)(125 \times 10^3) = -190 \times 10^3$ N

Area: $A = \frac{\pi}{4} d_2^2 = \frac{\pi}{4} (50 \times 10^{-3})^2 = 1.96350 \times 10^{-3} \text{ m}^2$

Normal stress: $\sigma_{BC} = \frac{P}{A} = \frac{-190 \times 10^3}{1.96350 \times 10^{-3}} = -96.766 \times 10^6 \text{ Pa}$ $\sigma_{BC} = -96.8 \text{ MPa} \blacktriangleleft$

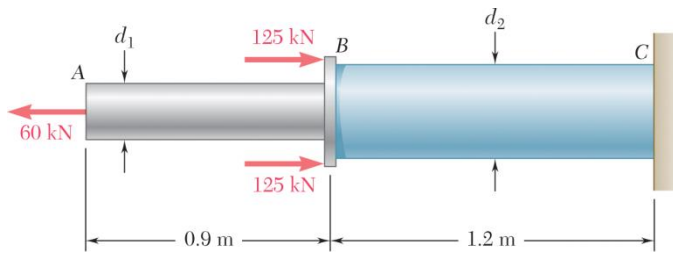

PROBLEM 1.2

Two solid cylindrical rods AB and BC are welded together at B and loaded as shown. Knowing that the average normal stress must not exceed 150 MPa in either rod, determine the smallest allowable values of the diameters d_1 and d_2 .

SOLUTION

(a) Rod AB :

Force: $P = 60 \times 10^3 \text{ N}$

Stress: $\sigma_{AB} = 150 \times 10^6 \text{ Pa}$

Area: $A = \frac{\pi}{4} d_1^2$

$$\sigma_{AB} = \frac{P}{A} \quad \therefore \quad A = \frac{P}{\sigma_{AB}}$$

$$\frac{\pi}{4} d_1^2 = \frac{P}{\sigma_{AB}}$$

$$d_1^2 = \frac{4P}{\pi\sigma_{AB}} = \frac{(4)(60 \times 10^3)}{\pi(150 \times 10^6)} = 509.30 \times 10^{-6} \text{ m}^2$$

$$d_1 = 22.568 \times 10^{-3} \text{ m}$$

$$d_1 = 22.6 \text{ mm} \quad \blacktriangleleft$$

(b) Rod BC :

Force: $P = 60 \times 10^3 - (2)(125 \times 10^3) = -190 \times 10^3 \text{ N}$

Stress: $\sigma_{BC} = -150 \times 10^6 \text{ Pa}$

Area: $A = \frac{\pi}{4} d_2^2$

$$\sigma_{BC} = \frac{P}{A} = \frac{4P}{\pi d_2^2}$$

$$d_2^2 = \frac{4P}{\pi\sigma_{BC}} = \frac{(4)(-190 \times 10^3)}{\pi(-150 \times 10^6)} = 1.61277 \times 10^{-3} \text{ m}^2$$

$$d_2 = 40.159 \times 10^{-3} \text{ m}$$

$$d_2 = 40.2 \text{ mm} \quad \blacktriangleleft$$

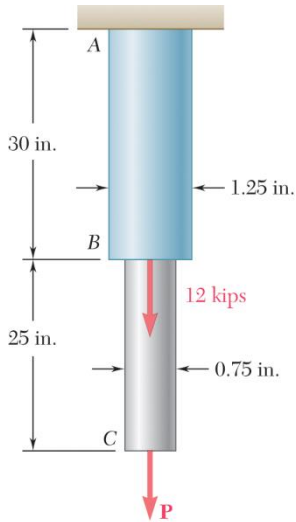

PROBLEM 1.3

Two solid cylindrical rods AB and BC are welded together at B and loaded as shown. Knowing that $P = 10$ kips, find the average normal stress at the midsection of (a) rod AB , (b) rod BC .

SOLUTION

(a) Rod AB :

$$P = 12 + 10 = 22 \text{ kips}$$

$$A = \frac{\pi}{4} d_1^2 = \frac{\pi}{4} (1.25)^2 = 1.22718 \text{ in}^2$$

$$\sigma_{AB} = \frac{P}{A} = \frac{22}{1.22718} = 17.927 \text{ ksi}$$

$$\sigma_{AB} = 17.93 \text{ ksi} \quad \blacktriangleleft$$

(b) Rod BC :

$$P = 10 \text{ kips}$$

$$A = \frac{\pi}{4} d_2^2 = \frac{\pi}{4} (0.75)^2 = 0.44179 \text{ in}^2$$

$$\sigma_{AB} = \frac{P}{A} = \frac{10}{0.44179} = 22.635 \text{ ksi}$$

$$\sigma_{AB} = 22.6 \text{ ksi} \quad \blacktriangleleft$$

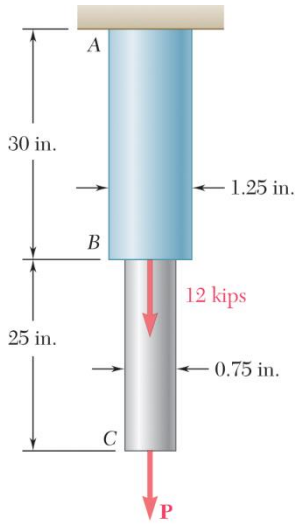

PROBLEM 1.4

Two solid cylindrical rods AB and BC are welded together at B and loaded as shown. Determine the magnitude of the force \mathbf{P} for which the tensile stresses in rods AB and BC are equal.

SOLUTION

(a) Rod AB :

$$P = P + 12 \text{ kips}$$

$$A = \frac{\pi d^2}{4} = \frac{\pi}{4} (1.25 \text{ in.})^2$$

$$A = 1.22718 \text{ in}^2$$

$$\sigma_{AB} = \frac{P + 12 \text{ kips}}{1.22718 \text{ in}^2}$$

(b) Rod BC :

$$P = P$$

$$A = \frac{\pi}{4} d^2 = \frac{\pi}{4} (0.75 \text{ in.})^2$$

$$A = 0.44179 \text{ in}^2$$

$$\sigma_{BC} = \frac{P}{0.44179 \text{ in}^2}$$

$$\sigma_{AB} = \sigma_{BC}$$

$$\frac{P + 12 \text{ kips}}{1.22718 \text{ in}^2} = \frac{P}{0.44179 \text{ in}^2}$$

$$5.3015 = 0.78539P$$

$$P = 6.75 \text{ kips} \blacktriangleleft$$

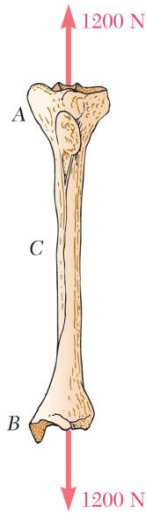

PROBLEM 1.5

A strain gage located at C on the surface of bone AB indicates that the average normal stress in the bone is 3.80 MPa when the bone is subjected to two 1200-N forces as shown. Assuming the cross section of the bone at C to be annular and knowing that its outer diameter is 25 mm, determine the inner diameter of the bone's cross section at C .

SOLUTION

$$\sigma = \frac{P}{A} \quad \therefore \quad A = \frac{P}{\sigma}$$

Geometry: $A = \frac{\pi}{4}(d_1^2 - d_2^2)$

$$d_2^2 = d_1^2 - \frac{4A}{\pi} = d_1^2 - \frac{4P}{\pi\sigma}$$

$$d_2^2 = (25 \times 10^{-3})^2 - \frac{(4)(1200)}{\pi(3.80 \times 10^6)}$$

$$= 222.92 \times 10^{-6} \text{ m}^2$$

$$d_2 = 14.93 \times 10^{-3} \text{ m}$$

$$d_2 = 14.93 \text{ mm} \quad \blacktriangleleft$$

PROBLEM 1.6

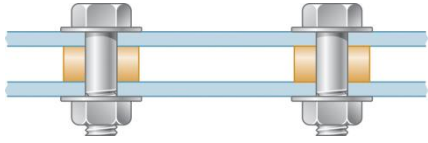

Two steel plates are to be held together by means of 16-mm-diameter high-strength steel bolts fitting snugly inside cylindrical brass spacers. Knowing that the average normal stress must not exceed 200 MPa in the bolts and 130 MPa in the spacers, determine the outer diameter of the spacers that yields the most economical and safe design.

SOLUTION

At each bolt location the upper plate is pulled down by the tensile force P_b of the bolt. At the same time, the spacer pushes that plate upward with a compressive force P_s in order to maintain equilibrium.

$$P_b = P_s$$

For the bolt,
$$\sigma_b = \frac{F_b}{A_b} = \frac{4P_b}{\pi d_b^2} \quad \text{or} \quad P_b = \frac{\pi}{4} \sigma_b d_b^2$$

For the spacer,
$$\sigma_s = \frac{P_s}{A_s} = \frac{4P_s}{\pi(d_s^2 - d_b^2)} \quad \text{or} \quad P_s = \frac{\pi}{4} \sigma_s (d_s^2 - d_b^2)$$

Equating P_b and P_s ,

$$\frac{\pi}{4} \sigma_b d_b^2 = \frac{\pi}{4} \sigma_s (d_s^2 - d_b^2)$$

$$d_s = \sqrt{\left(1 + \frac{\sigma_b}{\sigma_s}\right)} d_b = \sqrt{\left(1 + \frac{200}{130}\right)} (16) \quad d_s = 25.2 \text{ mm} \blacktriangleleft$$

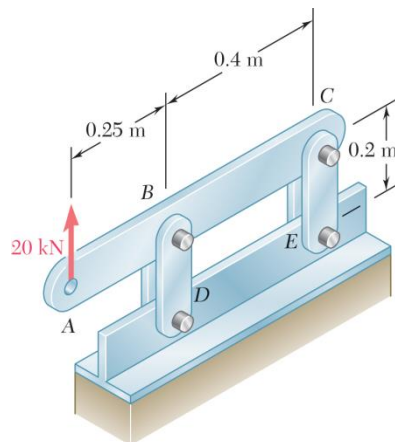

PROBLEM 1.7

Each of the four vertical links has an 8×36 -mm uniform rectangular cross section and each of the four pins has a 16-mm diameter. Determine the maximum value of the average normal stress in the links connecting (a) points B and D , (b) points C and E .

SOLUTION

Use bar ABC as a free body.

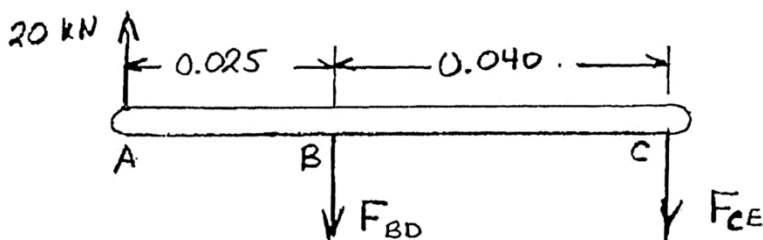

$$\Sigma M_C = 0 : (0.040) F_{BD} - (0.025 + 0.040)(20 \times 10^3) = 0$$

$$F_{BD} = 32.5 \times 10^3 \text{ N} \quad \text{Link } BD \text{ is in tension.}$$

$$\Sigma M_B = 0 : -(0.040) F_{CE} - (0.025)(20 \times 10^3) = 0$$

$$F_{CE} = -12.5 \times 10^3 \text{ N} \quad \text{Link } CE \text{ is in compression.}$$

$$\text{Net area of one link for tension} = (0.008)(0.036 - 0.016) = 160 \times 10^{-6} \text{ m}^2$$

$$\text{For two parallel links, } A_{\text{net}} = 320 \times 10^{-6} \text{ m}^2$$

$$(a) \quad \sigma_{BD} = \frac{F_{BD}}{A_{\text{net}}} = \frac{32.5 \times 10^3}{320 \times 10^{-6}} = 101.563 \times 10^6$$

$$\sigma_{BD} = 101.6 \text{ MPa} \quad \blacktriangleleft$$

$$\text{Area for one link in compression} = (0.008)(0.036) = 288 \times 10^{-6} \text{ m}^2$$

$$\text{For two parallel links, } A = 576 \times 10^{-6} \text{ m}^2$$

$$(b) \quad \sigma_{CE} = \frac{F_{CE}}{A} = \frac{-12.5 \times 10^3}{576 \times 10^{-6}} = -21.701 \times 10^6$$

$$\sigma_{CE} = -21.7 \text{ MPa} \quad \blacktriangleleft$$

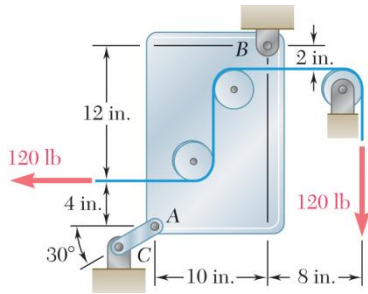

PROBLEM 1.8

Link AC has a uniform rectangular cross section $\frac{1}{8}$ in. thick and 1 in. wide. Determine the normal stress in the central portion of the link.

SOLUTION

Use the plate together with two pulleys as a free body. Note that the cable tension causes a 1200 lb-in. clockwise couple to act on the body.

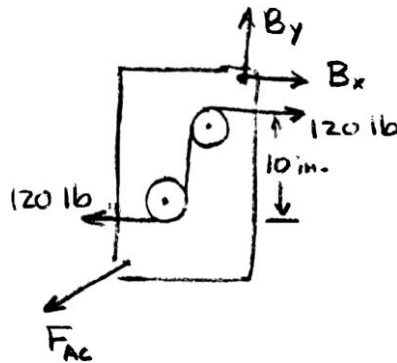

$$+\circlearrowleft \sum M_B = 0: \quad -(12 + 4)(F_{AC} \cos 30^\circ) + (10)(F_{AC} \sin 30^\circ) - 1200 \text{ lb} = 0$$

$$F_{AC} = -\frac{1200 \text{ lb}}{16 \cos 30^\circ - 10 \sin 30^\circ} = -135.500 \text{ lb}$$

Area of link AC: $A = 1 \text{ in.} \times \frac{1}{8} \text{ in.} = 0.125 \text{ in}^2$

Stress in link AC: $\sigma_{AC} = \frac{F_{AC}}{A} = -\frac{135.50}{0.125} = 1084 \text{ psi} = 1.084 \text{ ksi}$

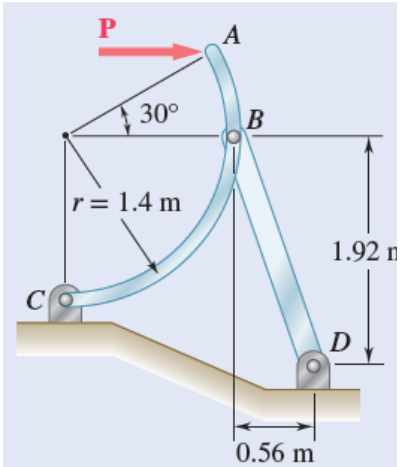

PROBLEM 1.9

Knowing that the central portion of the link BD has a uniform cross-sectional area of 800 mm^2 , determine the magnitude of the load P for which the normal stress in that portion of BD is 50 MPa .

SOLUTION

Draw free body diagram of link AC .

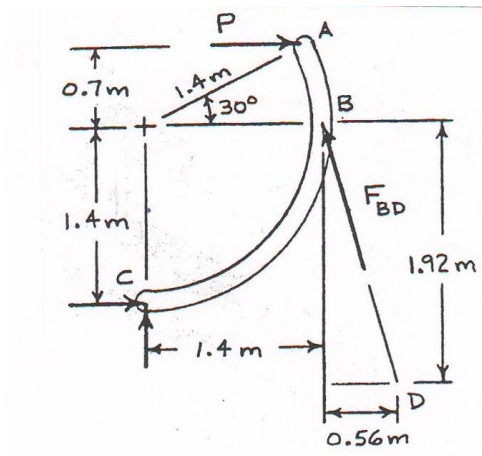

$$\begin{aligned}
 F_{BD} &= \sigma A \\
 &= (50 \times 10^6 \text{ N/m}^2)(800 \times 10^{-6} \text{ m}^2) \\
 &= 40 \times 10^3 \text{ N} \\
 BD &= \sqrt{(0.56 \text{ m})^2 + (1.92 \text{ m})^2} \\
 &= 2.00 \text{ m}
 \end{aligned}$$

Free Body AC:

$$\begin{aligned}
 \rightarrow M_C = 0: \quad & \frac{0.56}{2.00}(40 \times 10^3)(1.4) + \frac{1.92}{2.00}(40 \times 10^3)(1.4) - P(0.7 + 1.4) = 0 \\
 & P = 33.1 \times 10^3 \text{ N}
 \end{aligned}$$

$$P = 33.1 \text{ kN} \blacktriangleleft$$

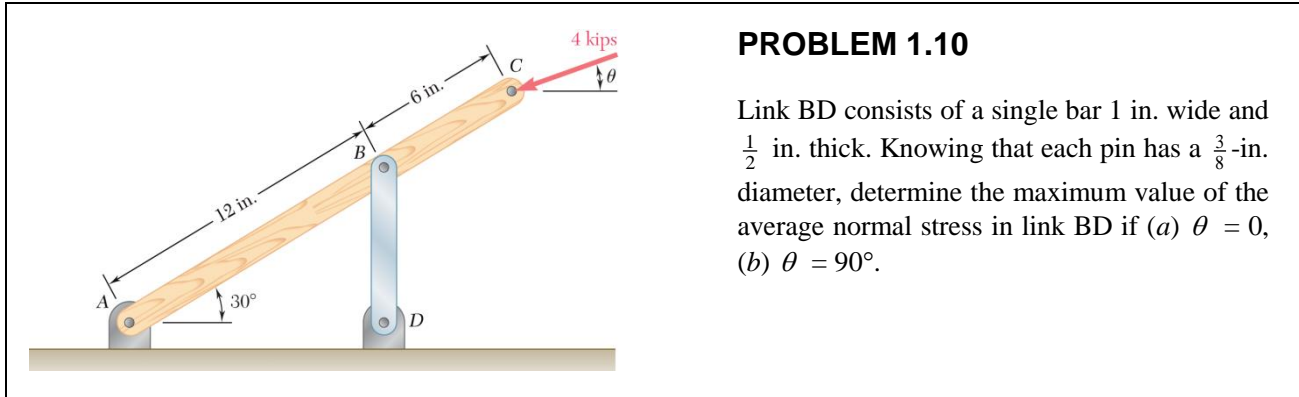

PROBLEM 1.10

Link BD consists of a single bar 1 in. wide and $\frac{1}{2}$ in. thick. Knowing that each pin has a $\frac{3}{8}$ -in. diameter, determine the maximum value of the average normal stress in link BD if (a) $\theta = 0$, (b) $\theta = 90^\circ$.

SOLUTION

Use bar ABC as a free body.

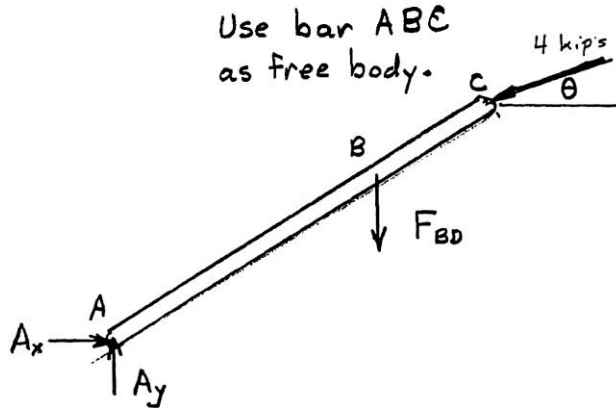

(a) $\theta = 0$.

$$+\circlearrowleft \sum M_A = 0: (18 \sin 30^\circ)(4) - (12 \cos 30^\circ)F_{BD} = 0$$

$$F_{BD} = 3.4641 \text{ kips (tension)}$$

Area for tension loading: $A = (b - d)t = \left(1 - \frac{3}{8}\right)\left(\frac{1}{2}\right) = 0.31250 \text{ in}^2$

Stress: $\sigma = \frac{F_{BD}}{A} = \frac{3.4641 \text{ kips}}{0.31250 \text{ in}^2} \quad \sigma = 11.09 \text{ ksi} \blacktriangleleft$

(b) $\theta = 90^\circ$.

$$+\circlearrowleft \sum M_A = 0: -(18 \cos 30^\circ)(4) - (12 \cos 30^\circ)F_{BD} = 0$$

$$F_{BD} = -6 \text{ kips i.e. compression.}$$

Area for compression loading: $A = bt = (1)\left(\frac{1}{2}\right) = 0.5 \text{ in}^2$

Stress: $\sigma = \frac{F_{BD}}{A} = \frac{-6 \text{ kips}}{0.5 \text{ in}^2} \quad \sigma = 12.00 \text{ ksi} \blacktriangleleft$

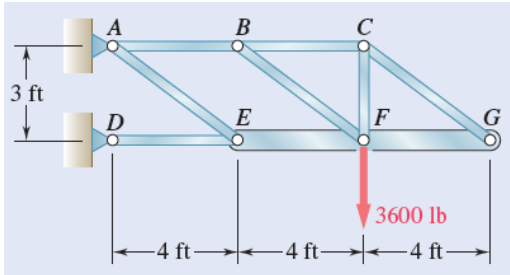

PROBLEM 1.11

The rigid bar EFG is supported by the truss system shown. Knowing that the member CG is a solid circular rod of 0.75-in. diameter, determine the normal stress in CG .

SOLUTION

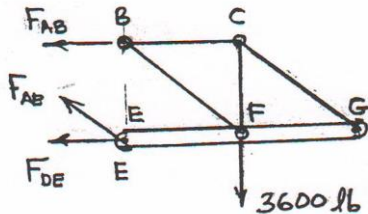

Using portion $EFGCB$ as free body,

$$+\uparrow \Sigma F_y = 0: \frac{3}{5} F_{AE} - 3600 = 0, \quad F_{AE} = 6000 \text{ lb}$$

Use beam EFG as free body.

$$+\curvearrowright \Sigma M_F = 0: -(4) \frac{3}{5} F_{AE} + (4) \frac{3}{5} F_{CG} = 0$$

$$F_{AE} = F_{CG} = 6000 \text{ lb}$$

Normal stress in member CG

$$\text{Area: } A = \frac{\pi d^2}{4} = 0.44179 \text{ in}^2$$

$$\sigma_{CG} = \frac{F}{A} = \frac{6000}{0.44179} = 13580 \text{ psi}$$

$$\sigma_{CG} = 13.58 \text{ ksi} \quad \blacktriangleleft$$

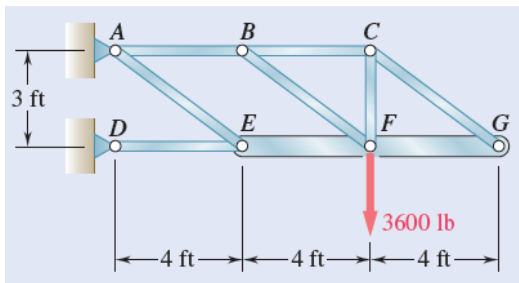

PROBLEM 1.12

The rigid bar EFG is supported by the truss system shown. Determine the cross-sectional area of member AE for which the normal stress in the member is 15 ksi.

SOLUTION

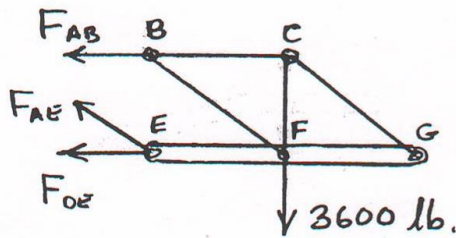

Using portion $EFGCB$ as free body,

$$+\uparrow \Sigma F_y = 0: \frac{3}{5} F_{AE} - 3600 = 0, \quad F_{AE} = 6000 \text{ lb}$$

Normal stress in member $AE = 15 \text{ ksi}$

$$\sigma_{AE} = \frac{F}{A}$$

$$A = \frac{F}{\sigma_{AE}} = \frac{6.00 \text{ kips}}{15 \text{ ksi}}$$

$$A = 0.400 \text{ in}^2 \quad \blacktriangleleft$$

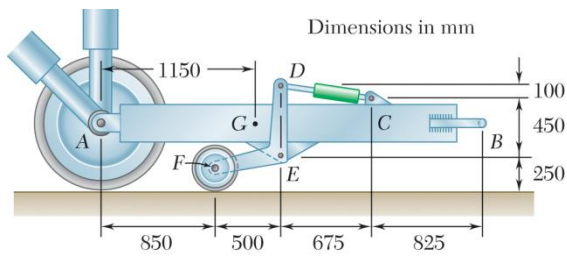

PROBLEM 1.13

An aircraft tow bar is positioned by means of a single hydraulic cylinder connected by a 25-mm-diameter steel rod to two identical arm-and-wheel units DEF . The mass of the entire tow bar is 200 kg, and its center of gravity is located at G . For the position shown, determine the normal stress in the rod.

SOLUTION

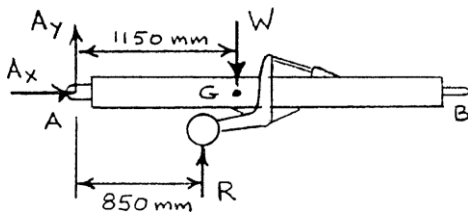

FREE BODY – ENTIRE TOW BAR:

$$W = (200 \text{ kg})(9.81 \text{ m/s}^2) = 1962.00 \text{ N}$$

$$+\circlearrowleft \Sigma M_A = 0: 850R - 1150(1962.00 \text{ N}) = 0$$

$$R = 2654.5 \text{ N}$$

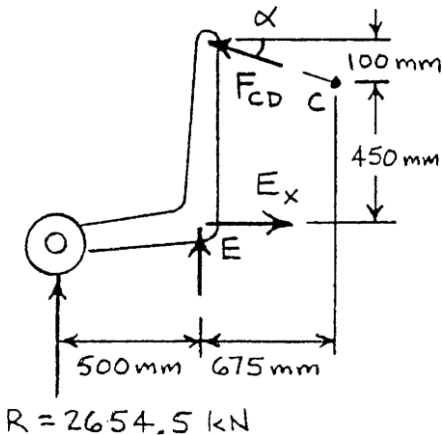

FREE BODY – BOTH ARM & WHEEL UNITS:

$$\tan \alpha = \frac{100}{675} \quad \alpha = 8.4270^\circ$$

$$+\circlearrowleft \Sigma M_E = 0: (F_{CD} \cos \alpha)(550) - R(500) = 0$$

$$F_{CD} = \frac{500}{550 \cos 8.4270^\circ} (2654.5 \text{ N})$$

$$= 2439.5 \text{ N (comp.)}$$

$$\sigma_{CD} = -\frac{F_{CD}}{A_{CD}} = -\frac{2439.5 \text{ N}}{\pi(0.0125 \text{ m})^2}$$

$$= -4.9697 \times 10^6 \text{ Pa} \quad \sigma_{CD} = -4.97 \text{ MPa} \quad \blacktriangleleft$$

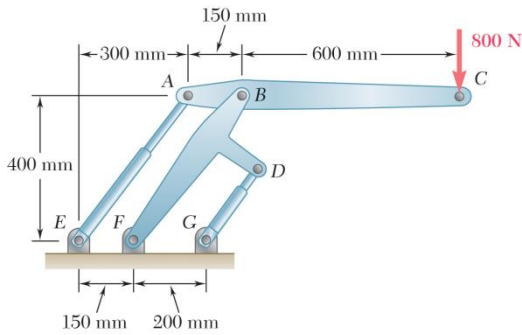

PROBLEM 1.14

Two hydraulic cylinders are used to control the position of the robotic arm ABC . Knowing that the control rods attached at A and D each have a 20-mm diameter and happen to be parallel in the position shown, determine the average normal stress in (a) member AE , (b) member DG .

SOLUTION

Use member ABC as free body.

Use member ABC
as free body.

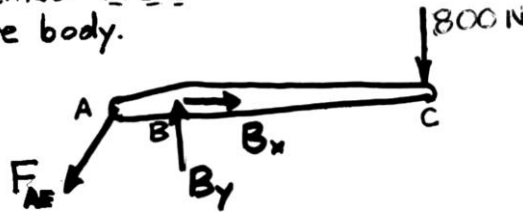

$$+\circlearrowleft \Sigma M_B = 0: (0.150) \frac{4}{5} F_{AE} - (0.600)(800) = 0$$

$$F_{AE} = 4 \times 10^3 \text{ N}$$

Area of rod in member AE is $A = \frac{\pi}{4} d^2 = \frac{\pi}{4} (20 \times 10^{-3})^2 = 314.16 \times 10^{-6} \text{ m}^2$

Stress in rod AE : $\sigma_{AE} = \frac{F_{AE}}{A} = \frac{4 \times 10^3}{314.16 \times 10^{-6}} = 12.7324 \times 10^6 \text{ Pa}$

(a) $\sigma_{AE} = 12.73 \text{ MPa} \blacktriangleleft$

Use combined members ABC and BFD as free body.

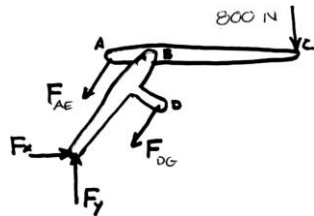

$$+\circlearrowleft \Sigma M_F = 0: (0.150) \left(\frac{4}{5} F_{AE} \right) - (0.200) \left(\frac{4}{5} F_{DG} \right) - (1.050 - 0.350)(800) = 0$$

$$F_{DG} = -1500 \text{ N}$$

Area of rod DG : $A = \frac{\pi}{4} d^2 = \frac{\pi}{4} (20 \times 10^{-3})^2 = 314.16 \times 10^{-6} \text{ m}^2$

Stress in rod DG : $\sigma_{DG} = \frac{F_{DG}}{A} = \frac{-1500}{3.1416 \times 10^{-6}} = -4.7746 \times 10^6 \text{ Pa}$

(b) $\sigma_{DG} = -4.77 \text{ MPa} \blacktriangleleft$

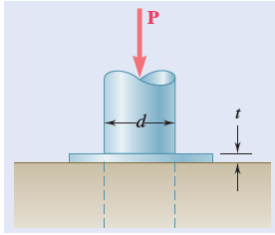

PROBLEM 1.15

Knowing that a force \mathbf{P} of magnitude 50 kN is required to punch a hole of diameter $d = 20$ mm in an aluminum sheet of thickness $t = 5$ mm, determine the average shearing stress in the aluminum at failure.

SOLUTION

Area of failure in plate:

$$\begin{aligned} A &= \pi dt = \pi(0.020 \text{ m})(0.005 \text{ m}) \\ &= 3.1416 \times 10^{-4} \text{ m}^2 \end{aligned}$$

Average shearing stress:

$$\begin{aligned} \tau_{\text{avg}} &= \frac{P}{A} \\ &= \frac{50 \times 10^3 \text{ N}}{3.1416 \times 10^{-4} \text{ m}^2} \end{aligned}$$

$$\tau_{\text{avg}} = 159.2 \text{ MPa} \quad \blacktriangleleft$$

PROBLEM 1.16

Two wooden planks, each $\frac{1}{2}$ in. thick and 9 in. wide, are joined by the dry mortise joint shown. Knowing that the wood used shears off along its grain when the average shearing stress reaches 1.20 ksi, determine the magnitude P of the axial load that will cause the joint to fail.

SOLUTION

Six areas must be sheared off when the joint fails. Each of these areas has dimensions $\frac{5}{8}$ in. \times $\frac{1}{2}$ in., its area being

$$A = \frac{5}{8} \times \frac{1}{2} = \frac{5}{16} \text{ in}^2 = 0.3125 \text{ in}^2$$

At failure, the force carried by each area is

$$F = \tau A = (1.20 \text{ ksi})(0.3125 \text{ in}^2) = 0.375 \text{ kips}$$

Since there are six failure areas,

$$P = 6F = (6)(0.375) \qquad P = 2.25 \text{ kips} \blacktriangleleft$$

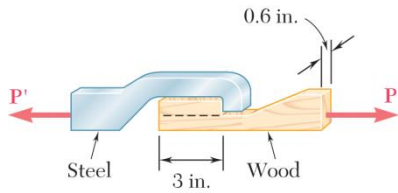

PROBLEM 1.17

When the force \mathbf{P} reached 1600 lb, the wooden specimen shown failed in shear along the surface indicated by the dashed line. Determine the average shearing stress along that surface at the time of failure.

SOLUTION

Area being sheared: $A = 3 \text{ in.} \times 0.6 \text{ in.} = 1.8 \text{ in}^2$

Force: $P = 1600 \text{ lb}$

Shearing stress: $\tau = \frac{P}{A} = \frac{1600 \text{ lb}}{1.8 \text{ in}^2} = 8.8889 \times 10^2 \text{ psi}$ $\tau = 889 \text{ psi} \blacktriangleleft$

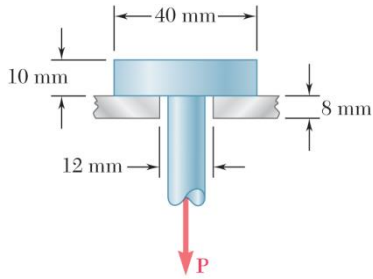

PROBLEM 1.18

A load P is applied to a steel rod supported as shown by an aluminum plate into which a 12-mm-diameter hole has been drilled. Knowing that the shearing stress must not exceed 180 MPa in the steel rod and 70 MPa in the aluminum plate, determine the largest load P that can be applied to the rod.

SOLUTION

For steel:

$$A_1 = \pi dt = \pi(0.012 \text{ m})(0.010 \text{ m}) \\ = 376.99 \times 10^{-6} \text{ m}^2$$

$$\tau_1 = \frac{P}{A} \therefore P = A_1 \tau_1 = (376.99 \times 10^{-6} \text{ m}^2)(180 \times 10^6 \text{ Pa}) \\ = 67.858 \times 10^3 \text{ N}$$

For aluminum:

$$A_2 = \pi dt = \pi(0.040 \text{ m})(0.008 \text{ m}) = 1.00531 \times 10^{-3} \text{ m}^2$$

$$\tau_2 = \frac{P}{A_2} \therefore P = A_2 \tau_2 = (1.00531 \times 10^{-3} \text{ m}^2)(70 \times 10^6 \text{ Pa}) = 70.372 \times 10^3 \text{ N}$$

Limiting value of P is the smaller value, so

$$P = 67.9 \text{ kN} \blacktriangleleft$$

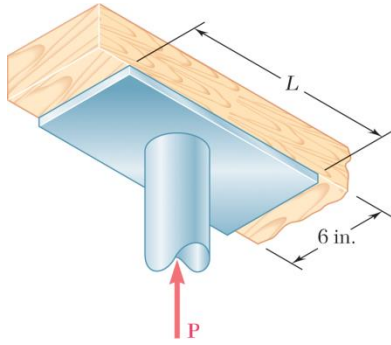

PROBLEM 1.19

The axial force in the column supporting the timber beam shown is $P = 20$ kips. Determine the smallest allowable length L of the bearing plate if the bearing stress in the timber is not to exceed 400 psi.

SOLUTION

Bearing area: $A_b = Lw$

$$\sigma_b = \frac{P}{A_b} = \frac{P}{Lw}$$

$$L = \frac{P}{\sigma_b w} = \frac{20 \times 10^3 \text{ lb}}{(400 \text{ psi})(6 \text{ in.})} = 8.33 \text{ in.}$$

$$L = 8.33 \text{ in.} \quad \blacktriangleleft$$

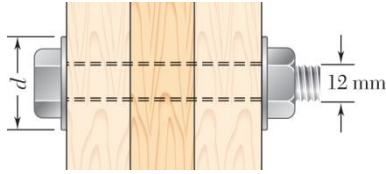

PROBLEM 1.20

Three wooden planks are fastened together by a series of bolts to form a column. The diameter of each bolt is 12 mm and the inner diameter of each washer is 16 mm, which is slightly larger than the diameter of the holes in the planks. Determine the smallest allowable outer diameter d of the washers, knowing that the average normal stress in the bolts is 36 MPa and that the bearing stress between the washers and the planks must not exceed 8.5 MPa.

SOLUTION

Bolt:
$$A_{\text{Bolt}} = \frac{\pi d^2}{4} = \frac{\pi(0.012 \text{ m})^2}{4} = 1.13097 \times 10^{-4} \text{ m}^2$$

Tensile force in bolt:
$$\sigma = \frac{P}{A} \Rightarrow P = \sigma A$$

$$= (36 \times 10^6 \text{ Pa})(1.13097 \times 10^{-4} \text{ m}^2)$$

$$= 4.0715 \times 10^3 \text{ N}$$

Bearing area for washer:
$$A_w = \frac{\pi}{4}(d_o^2 - d_i^2)$$

and
$$A_w = \frac{P}{\sigma_{BRG}}$$

Therefore, equating the two expressions for A_w gives

$$\frac{\pi}{4}(d_o^2 - d_i^2) = \frac{P}{\sigma_{BRG}}$$

$$d_o^2 = \frac{4P}{\pi\sigma_{BRG}} + d_i^2$$

$$d_o^2 = \frac{4(4.0715 \times 10^3 \text{ N})}{\pi(8.5 \times 10^6 \text{ Pa})} + (0.016 \text{ m})^2$$

$$d_o^2 = 8.6588 \times 10^{-4} \text{ m}^2$$

$$d_o = 29.426 \times 10^{-3} \text{ m}$$

$$d_o = 29.4 \text{ mm} \blacktriangleleft$$

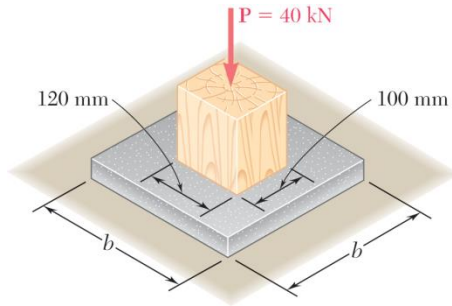

PROBLEM 1.21

A 40-kN axial load is applied to a short wooden post that is supported by a concrete footing resting on undisturbed soil. Determine (a) the maximum bearing stress on the concrete footing, (b) the size of the footing for which the average bearing stress in the soil is 145 kPa.

SOLUTION

(a) Bearing stress on concrete footing.

$$P = 40 \text{ kN} = 40 \times 10^3 \text{ N}$$

$$A = (100)(120) = 12 \times 10^3 \text{ mm}^2 = 12 \times 10^{-3} \text{ m}^2$$

$$\sigma = \frac{P}{A} = \frac{40 \times 10^3}{12 \times 10^{-3}} = 3.3333 \times 10^6 \text{ Pa} \quad 3.33 \text{ MPa} \blacktriangleleft$$

(b) Footing area. $P = 40 \times 10^3 \text{ N}$ $\sigma = 145 \text{ kPa} = 145 \times 10^3 \text{ Pa}$

$$\sigma = \frac{P}{A} \quad A = \frac{P}{\sigma} = \frac{40 \times 10^3}{145 \times 10^3} = 0.27586 \text{ m}^2$$

Since the area is square, $A = b^2$

$$b = \sqrt{A} = \sqrt{0.27586} = 0.525 \text{ m} \quad b = 525 \text{ mm} \blacktriangleleft$$

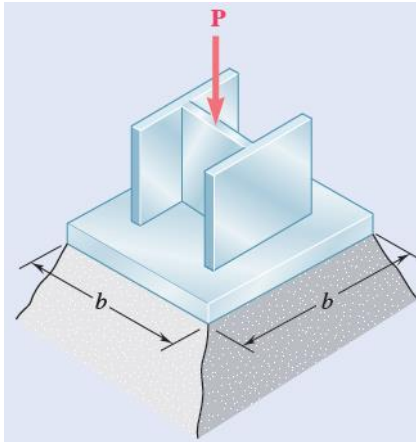

PROBLEM 1.22

The axial load $P = 240$ kips, supported by a $W10 \times 45$ column, is distributed to a concrete foundation by a square base plate as shown. Determine the size of the base plate for which the average bearing stress on the concrete is 750 psi.

SOLUTION

$$\begin{aligned}\sigma &= \frac{P}{A} \text{ or} \\ A &= \frac{P}{\sigma} \\ &= \frac{240 \times 10^3 \text{ lb}}{750 \text{ psi}} \\ &= 320 \text{ in}^2\end{aligned}$$

Since the plate is square,

$$\begin{aligned}A &= b^2 \\ b &= \sqrt{320 \text{ in}^2}\end{aligned}$$

$$b = 17.89 \text{ in.} \blacktriangleleft$$

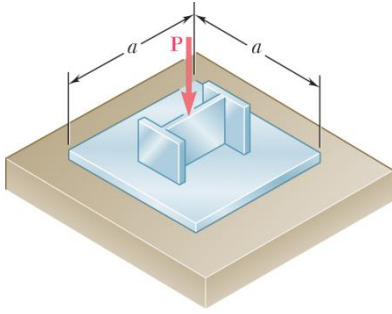

PROBLEM 1.23

An axial load P is supported by a short $W8 \times 40$ column of cross-sectional area $A = 11.7 \text{ in}^2$ and is distributed to a concrete foundation by a square plate as shown. Knowing that the average normal stress in the column must not exceed 30 ksi and that the bearing stress on the concrete foundation must not exceed 3.0 ksi, determine the side a of the plate that will provide the most economical and safe design.

SOLUTION

For the column, $\sigma = \frac{P}{A}$ or

$$P = \sigma A = (30)(11.7) = 351 \text{ kips}$$

For the $a \times a$ plate, $\sigma = 3.0 \text{ ksi}$

$$A = \frac{P}{\sigma} = \frac{351}{3.0} = 117 \text{ in}^2$$

Since the plate is square, $A = a^2$

$$a = \sqrt{A} = \sqrt{117}$$

$$a = 10.82 \text{ in.} \blacktriangleleft$$

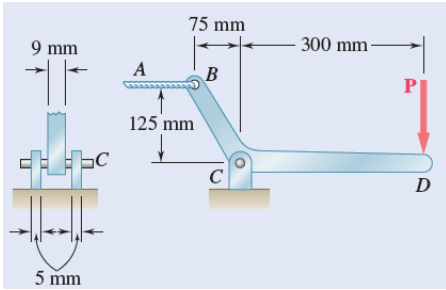

PROBLEM 1.24

A 6-mm-diameter pin is used at connection C of the pedal shown. Knowing that $P = 500$ N, determine (a) the average shearing stress in the pin, (b) the nominal bearing stress in the pedal at C, (c) the nominal bearing stress in each support bracket at C.

SOLUTION

Since BCD is a 3-force member, the reaction at C is directed toward E , the intersection of the lines of act of the other two forces.

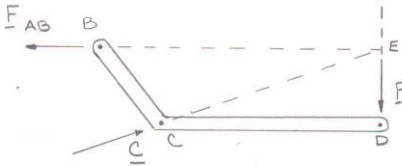

From geometry, $CE = \sqrt{300^2 + 125^2} = 325$ mm

From the free body diagram of BCD ,

$$+\uparrow \Sigma F_y = 0 : \frac{125}{325} C - P = 0 \quad C = 2.6P = 2.6(500 \text{ N}) = 1300 \text{ N}$$

$$(a) \quad \tau_{\text{pin}} = \frac{\frac{1}{2}C}{A_p} = \frac{\frac{1}{2}C}{\frac{\pi}{4}d^2} = \frac{2C}{\pi d^2}$$

$$\tau_{\text{pin}} = \frac{2(1300 \text{ N})}{\pi(6 \times 10^{-3} \text{ m})^2} = 23.0 \times 10^6 \text{ Pa}$$

$$\tau_{\text{pin}} = 23.0 \text{ MPa} \quad \blacktriangleleft$$

$$(b) \quad \sigma_b = \frac{C}{A_b} = \frac{C}{dt} = \frac{(1300)}{(6 \times 10^{-3})(9 \times 10^{-3})} = 24.1 \times 10^6 \text{ Pa}$$

$$\sigma_b = 24.1 \text{ MPa} \quad \blacktriangleleft$$

$$(c) \quad \sigma_b = \frac{\frac{1}{2}C}{A_b} = \frac{C}{2dt} = \frac{(1300)}{2(6 \times 10^{-3})(9 \times 10^{-3})} = 21.7 \times 10^6 \text{ Pa}$$

$$\sigma_b = 21.7 \text{ MPa} \blacktriangleleft$$

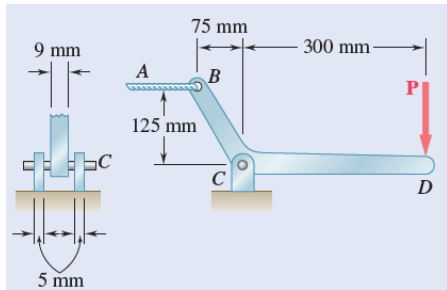

PROBLEM 1.25

Knowing that a force \mathbf{P} of magnitude 750 N is applied to the pedal shown, determine (a) the diameter of the pin at C for which the average shearing stress in the pin is 40 MPa, (b) the corresponding bearing stress in the pedal at C , (c) the corresponding bearing stress in each support bracket at C .

SOLUTION

Since BCD is a 3-force member, the reaction at C is directed toward E , the intersection of the lines of action of the other two forces.

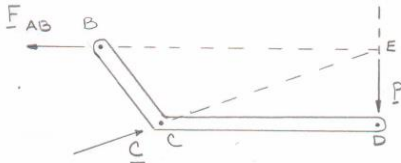

From geometry, $CE = \sqrt{300^2 + 125^2} = 325 \text{ mm}$

From the free body diagram of BCD ,

$$+\uparrow \Sigma F_y = 0 : \frac{125}{325} C - P = 0 \quad C = 2.6P = 2.6(750 \text{ N}) = 1950 \text{ N}$$

$$(a) \quad \tau_{\text{pin}} = \frac{\frac{1}{2}C}{A_p} = \frac{\frac{1}{2}C}{\frac{\pi}{4}d^2} = \frac{2C}{\pi d^2}$$

$$d = \sqrt{\frac{2C}{\pi \tau_{\text{pin}}}} = \sqrt{\frac{2(1950 \text{ N})}{\pi(40 \times 10^6 \text{ Pa})}} = 5.57 \times 10^{-3} \text{ m}$$

$$d = 5.57 \text{ mm} \quad \blacktriangleleft$$

$$(b) \quad \sigma_b = \frac{C}{A_b} = \frac{C}{dt} = \frac{(1950)}{(5.57 \times 10^{-3})(9 \times 10^{-3})} = 38.9 \times 10^6 \text{ Pa}$$

$$\sigma_b = 38.9 \text{ MPa} \quad \blacktriangleleft$$

$$(c) \quad \sigma_b = \frac{\frac{1}{2}C}{A_b} = \frac{C}{2dt} = \frac{(1950)}{2(5.57 \times 10^{-3})(5 \times 10^{-3})} = 35.0 \times 10^6 \text{ Pa}$$

$$\sigma_b = 35.0 \text{ MPa} \blacktriangleleft$$

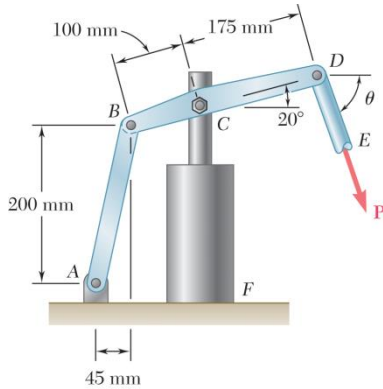

PROBLEM 1.26

The hydraulic cylinder CF , which partially controls the position of rod DE , has been locked in the position shown. Member BD is 15 mm thick and is connected at C to the vertical rod by a 9-mm-diameter bolt. Knowing that $P = 2$ kN and $\theta = 75^\circ$, determine (a) the average shearing stress in the bolt, (b) the bearing stress at C in member BD .

SOLUTION

Free Body: Member BD .

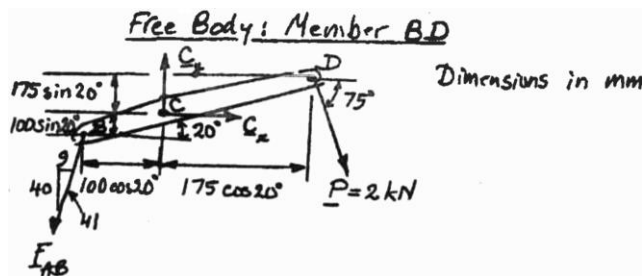

$$\begin{aligned}
 +\circlearrowleft \Sigma M_C = 0: & \quad \frac{40}{41} F_{AB} (100 \cos 20^\circ) - \frac{9}{41} F_{AB} (100 \sin 20^\circ) \\
 & \quad - (2 \text{ kN}) \cos 75^\circ (175 \sin 20^\circ) - (2 \text{ kN}) \sin 75^\circ (175 \cos 20^\circ) = 0 \\
 \frac{100}{41} F_{AB} (40 \cos 20^\circ - 9 \sin 20^\circ) & \quad = (2 \text{ kN})(175) \sin(75^\circ + 20^\circ) \\
 F_{AB} & \quad = 4.1424 \text{ kN}
 \end{aligned}$$

$$\begin{aligned}
 +\rightarrow \Sigma F_x = 0: & \quad C_x - \frac{9}{41} (4.1424 \text{ kN}) + (2 \text{ kN}) \cos 75^\circ = 0 \\
 C_x & \quad = 0.39167 \text{ kN}
 \end{aligned}$$

$$\begin{aligned}
 +\uparrow \Sigma F_y = 0: & \quad C_y - \frac{40}{41} (4.1424 \text{ kN}) - (2 \text{ kN}) \sin 75^\circ = 0 \\
 C_y & \quad = 5.9732 \text{ kN} \\
 \mathbf{C} & \quad = 5.9860 \text{ kN} \angle 86.2^\circ
 \end{aligned}$$

$$(a) \quad \tau_{\text{ave}} = \frac{C}{A} = \frac{5.9860 \times 10^3 \text{ N}}{\pi (0.0045 \text{ m})^2} = 94.1 \times 10^6 \text{ Pa} = 94.1 \text{ MPa} \quad \blacktriangleleft$$

$$(b) \quad \tau_b = \frac{C}{td} = \frac{5.9860 \times 10^3 \text{ N}}{(0.015 \text{ m})(0.009 \text{ m})} = 44.3 \times 10^6 \text{ Pa} = 44.3 \text{ MPa} \quad \blacktriangleleft$$

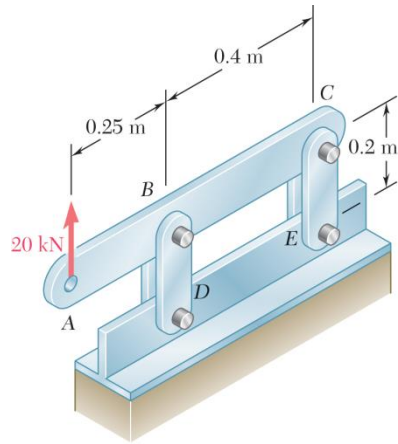

PROBLEM 1.27

For the assembly and loading of Prob. 1.7, determine (a) the average shearing stress in the pin at B, (b) the average bearing stress at B in member BD, (c) the average bearing stress at B in member ABC, knowing that this member has a 10×50 -mm uniform rectangular cross section.

PROBLEM 1.7 Each of the four vertical links has an 8×36 -mm uniform rectangular cross section and each of the four pins has a 16-mm diameter. Determine the maximum value of the average normal stress in the links connecting (a) points B and D, (b) points C and E.

SOLUTION

Use bar ABC as a free body.

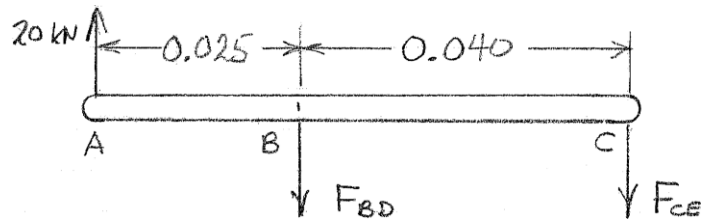

$$+\circlearrowleft \Sigma M_C = 0 : (0.040)F_{BD} - (0.025 + 0.040)(20 \times 10^3) = 0$$

$$F_{BD} = 32.5 \times 10^3 \text{ N}$$

(a) Shear pin at B. $\tau = \frac{F_{BD}}{2A}$ for double shear

where $A = \frac{\pi}{4}d^2 = \frac{\pi}{4}(0.016)^2 = 201.06 \times 10^{-6} \text{ m}^2$

$$\tau = \frac{32.5 \times 10^3}{(2)(201.06 \times 10^{-6})} = 80.822 \times 10^6 \text{ Pa} \quad \tau = 80.8 \text{ MPa} \quad \blacktriangleleft$$

(b) Bearing: link BD. $A = dt = (0.016)(0.008) = 128 \times 10^{-6} \text{ m}^2$

$$\sigma_b = \frac{\frac{1}{2}F_{BD}}{A} = \frac{(0.5)(32.5 \times 10^3)}{128 \times 10^{-6}} = 126.95 \times 10^6 \text{ Pa} \quad \sigma_b = 127.0 \text{ MPa} \quad \blacktriangleleft$$

(c) Bearing in ABC at B. $A = dt = (0.016)(0.010) = 160 \times 10^{-6} \text{ m}^2$

$$\sigma_b = \frac{F_{BD}}{A} = \frac{32.5 \times 10^3}{160 \times 10^{-6}} = 203.12 \times 10^6 \text{ Pa} \quad \sigma_b = 203 \text{ MPa} \quad \blacktriangleleft$$

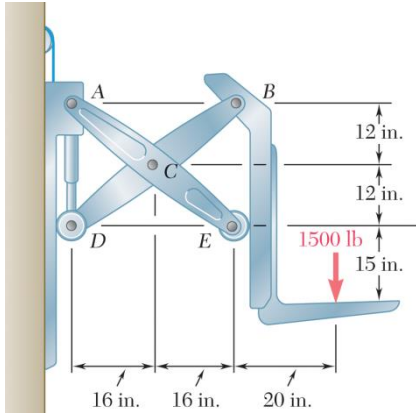

PROBLEM 1.28

Two identical linkage-and-hydraulic-cylinder systems control the position of the forks of a fork-lift truck. The load supported by the one system shown is 1500 lb. Knowing that the thickness of member BD is $\frac{5}{8}$ in., determine (a) the average shearing stress in the $\frac{1}{2}$ -in.-diameter pin at B , (b) the bearing stress at B in member BD .

SOLUTION

Use one fork as a free body.

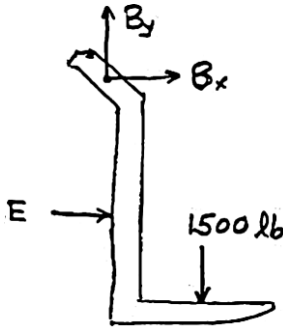

$$+\circlearrowleft \Sigma M_B = 0: 24E - (20)(1500) = 0$$

$$E = 1250 \text{ lb} \rightarrow$$

$$\pm \rightarrow \Sigma F_x = 0: E + B_x = 0$$

$$B_x = -E$$

$$B_x = 1250 \text{ lb} \leftarrow$$

$$+\uparrow \Sigma F_y = 0: B_y - 1500 = 0 \quad B_y = 1500 \text{ lb}$$

$$B = \sqrt{B_x^2 + B_y^2} = \sqrt{1250^2 + 1500^2} = 1952.56 \text{ lb}$$

(a) Shearing stress in pin at B .

$$A_{\text{pin}} = \frac{\pi}{4} d_{\text{pin}}^2 = \frac{\pi}{4} \left(\frac{1}{2} \right)^2 = 0.196350 \text{ in}^2$$

$$\tau = \frac{B}{A_{\text{pin}}} = \frac{1952.56}{0.196350} = 9.94 \times 10^3 \text{ psi}$$

$$\tau = 9.94 \text{ ksi} \blacktriangleleft$$

(b) Bearing stress at B .

$$\sigma = \frac{B}{dt} = \frac{1952.56}{\left(\frac{1}{2} \right) \left(\frac{5}{8} \right)} = 6.25 \times 10^3 \text{ psi}$$

$$\sigma = 6.25 \text{ ksi} \blacktriangleleft$$

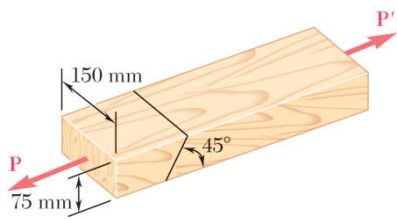

PROBLEM 1.29

Two wooden members of uniform rectangular cross section are joined by the simple glued scarf splice shown. Knowing that $P = 11$ kN, determine the normal and shearing stresses in the glued splice.

SOLUTION

$$\theta = 90^\circ - 45^\circ = 45^\circ$$

$$P = 11 \text{ kN} = 11 \times 10^3 \text{ N}$$

$$A_0 = (150)(75) = 11.25 \times 10^3 \text{ mm}^2 = 11.25 \times 10^{-3} \text{ m}^2$$

$$\sigma = \frac{P \cos^2 \theta}{A_0} = \frac{(11 \times 10^3) \cos^2 45^\circ}{11.25 \times 10^{-3}} = 489 \times 10^3 \text{ Pa} \quad \sigma = 489 \text{ kPa} \quad \blacktriangleleft$$

$$\tau = \frac{P \sin 2\theta}{2A_0} = \frac{(11 \times 10^3)(\sin 90^\circ)}{(2)(11.25 \times 10^{-3})} = 489 \times 10^3 \text{ Pa} \quad \tau = 489 \text{ kPa} \quad \blacktriangleleft$$

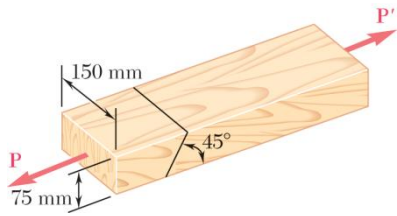

PROBLEM 1.30

Two wooden members of uniform rectangular cross section are joined by the simple glued scarf splice shown. Knowing that the maximum allowable shearing stress in the glued splice is 620 kPa, determine (a) the largest load **P** that can be safely applied, (b) the corresponding tensile stress in the splice.

SOLUTION

$$\theta = 90^\circ - 45^\circ = 45^\circ$$

$$A_0 = (150)(75) = 11.25 \times 10^3 \text{ mm}^2 = 11.25 \times 10^{-3} \text{ m}^2$$

$$\tau = 620 \text{ kPa} = 620 \times 10^3 \text{ Pa}$$

$$\tau = \frac{P \sin 2\theta}{2A_0}$$

$$(a) \quad P = \frac{2A_0\tau}{\sin 2\theta} = \frac{(2)(11.25 \times 10^{-3})(620 \times 10^3)}{\sin 90^\circ}$$

$$= 13.95 \times 10^3 \text{ N}$$

$$P = 13.95 \text{ kN} \quad \blacktriangleleft$$

$$(b) \quad \sigma = \frac{P \cos^2 \theta}{A_0} = \frac{(13.95 \times 10^3)(\cos 45^\circ)^2}{11.25 \times 10^{-3}}$$

$$= 620 \times 10^3 \text{ Pa}$$

$$\sigma = 620 \text{ kPa} \quad \blacktriangleleft$$